

## DIMENSIONS (mm/in.)

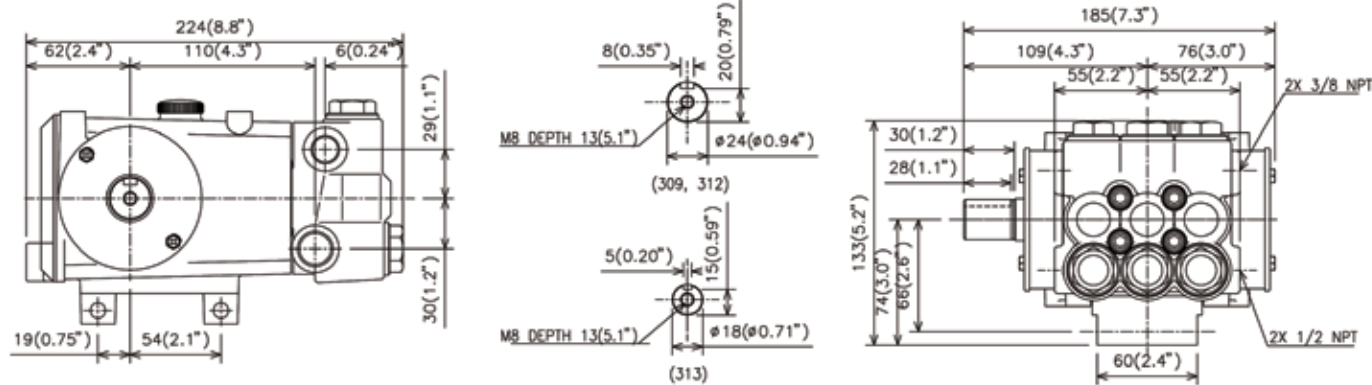

## CUTAWAY

- 1 High strength, lightweight die cast crankcase
- 2 Oversized crankshaft bearings for long life and quiet operation
- 3 Forged crankshaft is machined for low friction, quiet operation and high efficiency
- 4 High strength connecting rods are tolerance matched for extended life and low friction operation
- 5 High polish stainless steel plunger rods for smooth operation and even wear
- 6 Zero clearance, polymer exclusionary seal protects pump crankcase from fluid entry and will not corrode
- 7 Proprietary blend, solid ceramic plungers for long wear and increased thermal shock resistance
- 8 Forged brass manifolds for strength and corrosion resistance, machined to optimize fluid flow and performance while extending useful life
- 9 Liquid-cooled, low drag seals provide long life, extended run-dry ability and increased suction lift
- 10 Stainless steel valves with polished valve seats and hardened seating surfaces for efficient operation
- 11 Mechanically-loaded seals require no adjustment and self-compensate for wear
- 12 Balanced flow crankcase ensures lubrication and quiet operation
- 13 Slide-in seal cases mean no special tools are required, making seal replacement easy

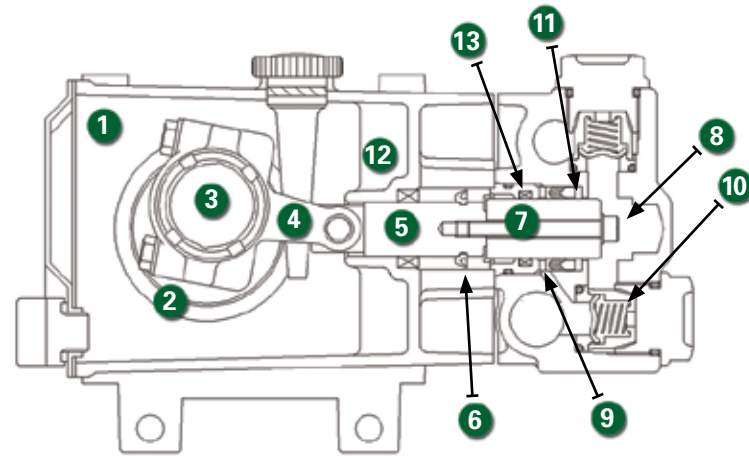

Arimitsu of North America, Inc.  
 700 McKinley St. NW  
 Anoka, MN 55303  
 ph: 763.433.0303  
 fax: 763.433.0404  
 www.arimitsupumps.com

Manufactured by Arimitsu Industry Co., Ltd., of Osaka, Japan, a leading supplier of Industrial plunger pumps and systems used by Industrial leaders throughout the World.



Rev.2, 3 Series, (2-06)  
 Part #. 102



## 3 Series Models 309, 312 and 313

## FEATURES

- Triplex pumps provide smooth liquid flow
- Liquid cooled, low drag seals provide long life, improved suction, higher efficiency and longer dry running without damage
- Balanced flow crankcase design and precision machining ensure uniform lubrication and quiet operation
- Manifold is designed and machined to guarantee superior fluid flow
- Interchangeable valves for maintenance ease
- Zero-clearance exclusionary seals protect crankcase

## QUALITY

- Stainless steel valves with polished valve seats and hardened seating surfaces for efficient operation
- Precision ground ceramic plungers utilize a proprietary material blend for long life and increased thermal shock resistance
- Forged brass manifolds offer strength and corrosion resistance
- Proprietary, proven seal blend maximizes life and lengthens maintenance intervals
- Oversized crankshaft bearings for long life and quiet operation

## MAINTENANCE

- No special tools required for repair or maintenance
- Fluid end is easily serviced without entering crankcase
- Easy access seal case and valve assemblies
- Seals self-compensate for wear

## MODEL SPECIFICATIONS

Model 309	US	METRIC
Flow	3.7 gpm	14 lpm
Pressure	1500 psi	105 bar
RPM	1725	1725
Shaft	.945"	24mm
Inlet Pressure	Flooded to 70 psi	0 to 5 bar
Model 312		
Flow	5 gpm	19 lpm
Pressure	1500 psi	105 bar
RPM	1725	1725
Shaft	.945"	24mm
Inlet Pressure	Flooded to 70 psi	0-5 bar
Model 313		
Flow	4 gpm	15 lpm
Pressure	1500 psi	105 bar
RPM	1050	1050
Shaft	.709"	18mm
Inlet Pressure	-5 to 70 psi	0-5 bar
Common Specifications		
Inlet	1/2"	1/2"
Outlet	3/8"	3/8"
Oil Requirement	17 oz	.5 liter
Max Liquid Temp.	175°F	80°C
Shaft Location	L or R	L or R
Weight	17 lbs	7.5 kg

# Parts List

REF. #	PART NUMBER	PART NAME	MATERIAL	QTY
F01	0121001010	MANIFOLD	FORGED BRASS	1
F05	0122211200	SEAL RETAINER	BRASS	3
F06	01222014000A	SEAL ASSEMBLY		3
F08	(included in F06)	V-PACKING	NBR/TEXTILE	3
F09	(included in F06)	VACUUM SEAL	NBR	3
F22	0122711430	SPREADER	BRASS	3
F23	0122201450	WAVE WASHER	STAINLESS	3
F25	9203B15026	O-RING, RETAINER	NBR	3
F30	0121001130	BOLT, 6MM	PLATED STEEL	4
F40	0121003300	VALVE ASSEMBLY		6
F41	(included in F40)	SEAT	STAINLESS	6
F42	0362003340	O-RING	NBR	6
F43	(included in F40)	POPPET	STAINLESS	6
F44	(included in F40)	SPRING	STAINLESS	6
F45	(included in F40)	CAGE	STAINLESS	6
F48	9201F20020	O-RING, VALVE CAP	NBR	6
F49	0120003230	VALVE CAP	FORGED BRASS	6
P05	0122052010	CRANKCASE	ALUMINUM	1
P07	01220020401	BACK COVER	PLATED STEEL	1
P08	0120002050	GASKET	BONDED PAPER	1
P09	9138A05015	SCREW, PHILLIPS	PLATED STEEL	8
P25	0090002320	DRAIN PLUG	FP	1
P26	0090002340	GASKET, DRAIN PLUG	NBR	1
P29	01300026000A	OIL DIPSTICK ASSEMBLY	FP	1
P31	9201B20016	O-RING, DIPSTICK	NBR	1
P37	0122051730	WATER SLINGER	NBR	3
P40	01200024001A	OIL SEAL ASSEMBLY	NBR	3
P50	0122844010	CRANKSHAFT (309)	STEEL	1
	0122454010	CRANKSHAFT (312)	STEEL	1
	0122140101	CRANKSHAFT (313)	STEEL	1
P51	9180630500	BEARING, BALL	STEEL	2
P53	0256004030	OIL SEAL, SHAFT SIDE	NBR	1
P54	0256104430	OIL SEAL, COVER	NBR	1
P56	0122004600	CON-ROD ASSEMBLY	ALUMINUM	3
P60	01220547S0	PLUNGER ASSEMBLY		3
P61	(included in F60)	ROD	STAINLESS	3
P62	(included in F60)	PLUNGER	CERAMIC	3
P63	(included in F60)	SPACER	BRASS	3
P66	(included in F60)	BOLT	STAINLESS	3
P64	0121114852	GASKET	COPPER	3
P65	0030004900	PIN, PLUNGER	STEEL	3
P70	02560044201	COVER, BEARING	PLATED STEEL	2
P80	0150008050A	SHAFT KEY, STEPPED	STEEL	1

\* Material listed may be a proprietary version. Parts names without part numbers are only available within complete assemblies.  
 \* Material codes: FP=Flouropolymer, NBR=Medium Nitrile (Buna-N), STAINLESS=Stainless Steel (300 Series)

# Exploded View

Models 309, 312, 313

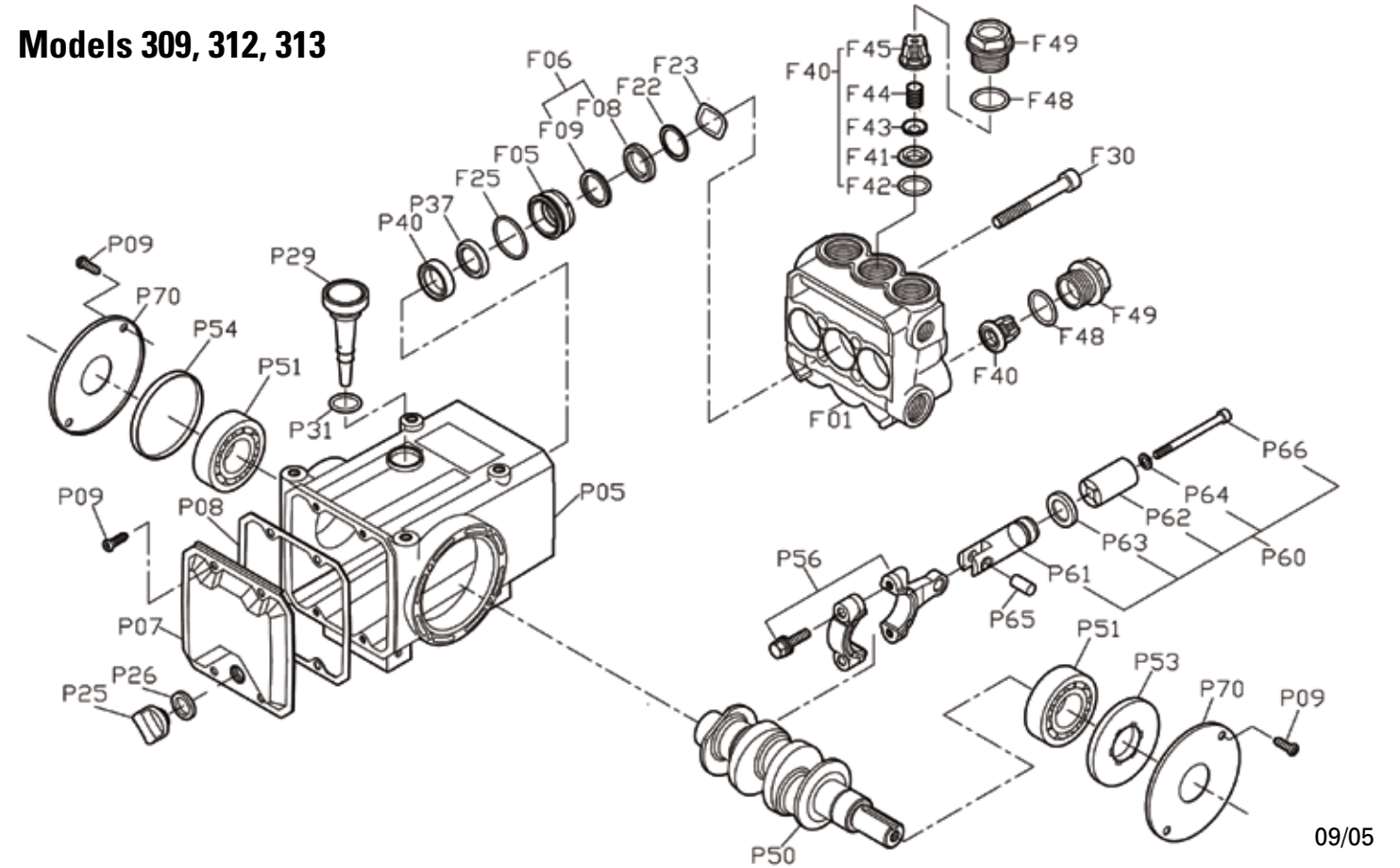

REF. #	PART NUMBER	PART NAME	MATERIAL	QTY
	30114	SEAL KIT, (F06, F25)	NBR	1
	30108	VALVE KIT, (F40)	STAINLESS/FP	2
	30102	RAIL, STANDARD	PLATED STEEL	2
	30113	RAIL, 310/5CP REPLACEMENT (SET)	PLATED STEEL	1
	30103	OIL, BOTTLE (32 OZ) ISO 100		1
Recommended Accessories (309 & 312 only)				
	70201	CLUTCH KIT, 7" SINGLE GROOVE, 24mm	STEEL	1

## Horsepower Requirements

	RPM			Pressure (psi)				
	GPM	LPM		800	1000	1200	1400	1500
<b>309</b>	600	1.3	5.1	0.7	0.9	1.1	1.2	1.3
	1400	3.0	11.9	1.6	2.0	2.5	2.9	3.1
	1725	3.7	14.6	2.0	2.5	3.0	3.5	3.8
<b>312</b>	1000	3.0	11.8	1.6	2.0	2.4	2.8	3.0
	1350	4.0	15.9	2.2	2.7	3.3	3.8	4.1
	1725	5.1	20.3	2.8	3.5	4.2		
<b>313</b>	950	3.6	14.3	2.0	2.5	3.0	3.5	3.7
	1050	4.0	15.8	2.2	2.7	3.3	3.8	4.1
	1450	5.5	21.9	3.0	3.8	4.5		

## Formulas

$$\text{Determining Pump RPM} = \frac{\text{Rated GPM}}{\text{Rated RPM}} = \frac{\text{"Desired" GPM}}{\text{"Desired" RPM}}$$

$$\text{Determining Required HP} = \frac{\text{GPM} \times \text{PSI}}{1460} = \text{Electric Brake H.P. Required}$$

$$\text{Determining Motor Pulley Size} = \frac{\text{Motor Pulley OD}}{\text{Pump RPM}} = \frac{\text{Pump Pulley OD}}{\text{Motor RPM}}$$